

# IMPROVING WEIGH FEEDER CONTROL USING SCALE LOCATION COMPENSATION

(March 4, 2000)

Thayer Scale, Hyer Industries, Inc.  
Robert L. Villano, Electrical Engineering Manager  
Pembroke, MA, USA

## Introductions:

This paper describes how "Scale Location Compensation" can be used to improve weigh feeder performance in various applications.

Scale Location Compensation ("SLC") was developed by Thayer Scale to meet special systems needs in 1976 (1) (2) (3) (4), and is used in control loops to effectively move the point of measurement and control from the scale's physical location on the conveyor belt to some downstream point which better serves the response needs of a downstream process.

## FUNDAMENTAL EXAMPLES OF MEASUREMENT & CONTROL UNCERTAINTY:

1. Uncertainty of Control of Discharging flow from a variable speed weighbelt feeder.

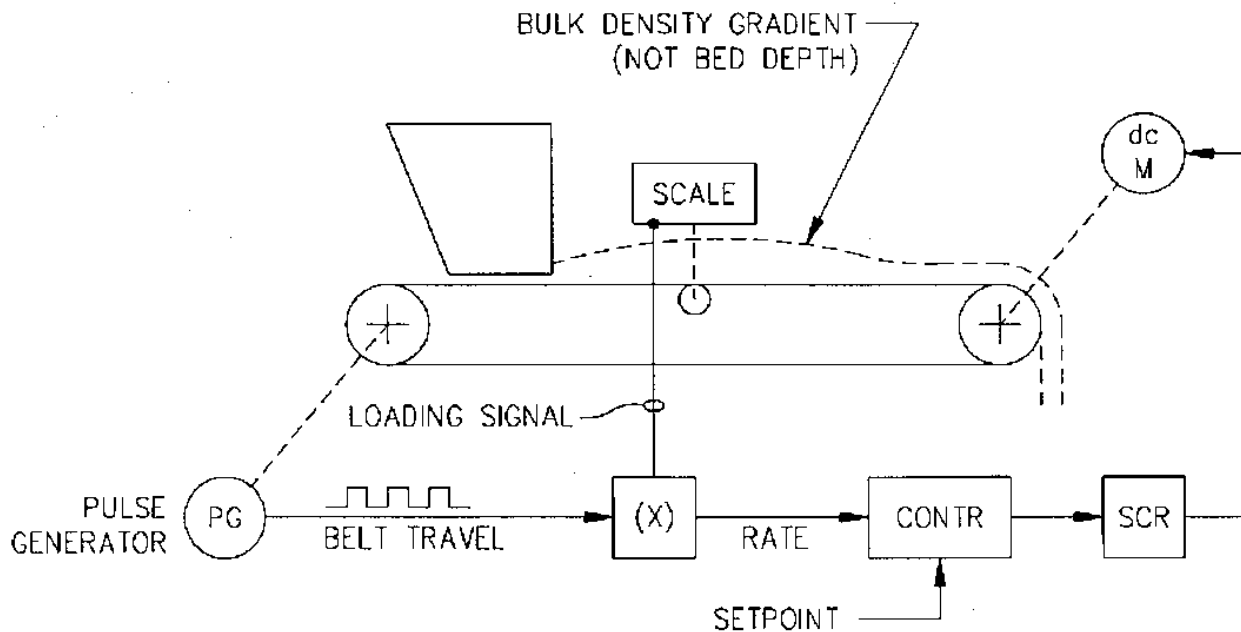

Note that heavy loading at scale calls for slower belt speed, yet light loading at head pulley requires opposite response if desired flow rate is to be achieved at the discharge.

2. Uncertainty of Measurement of Discharging flow from load-out conveyors.

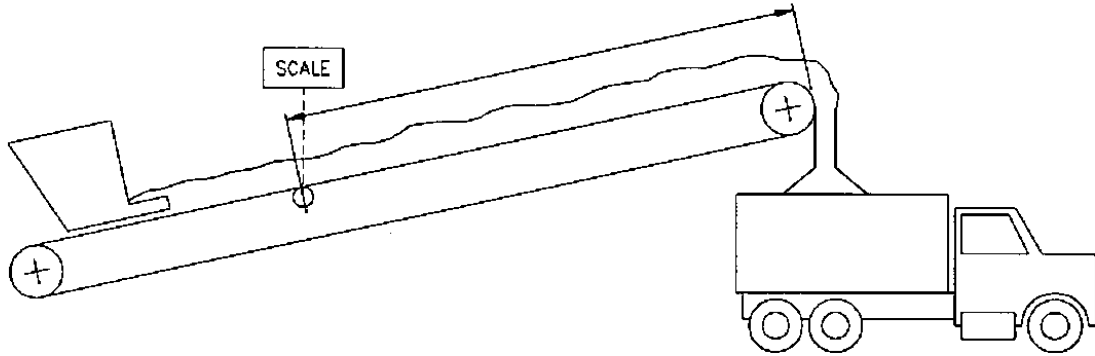

Note that conveyor scale is located near tail end, where belt tension is lowest, to assure best accuracy. Thus, all the material between scale and head pulley has been totalized but not delivered.

3. Uncertainty of Instantaneous Blend Control of additives to primary flows

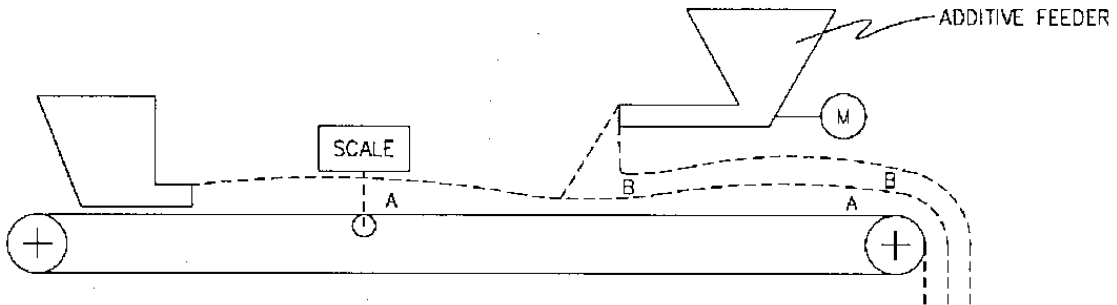

Note that heavy load at belt scale calls for proportionately greater additive feed, yet low loading at additive feeder's location requires an opposite response if instantaneous blend control is to be maintained. While these three examples meet different objectives, the basic problem that faces the process engineer in each case is the same:

"The possible location(s) for the scale(s) in a conveyor weighing system are not generally well suited to the final needs of the process due to considerations of accuracy, space availability, or practicality of layout."

## THE SCALE LOCATION COMPENSATOR (SLC)

Scale Location Compensator ("SLC") is the name given to the control element that provides for the Positional Transformation of weight data.

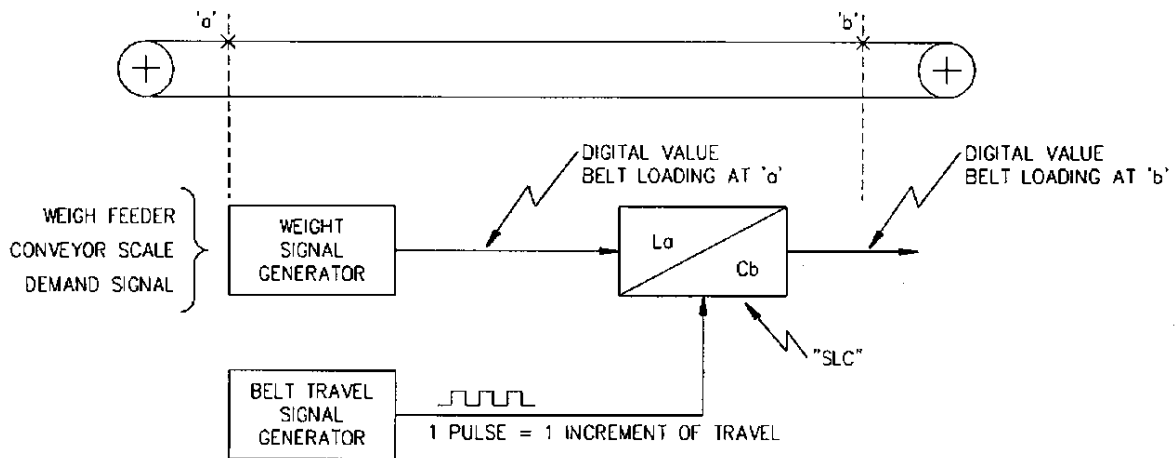

The "weight" signal may come from any continuous weighing or feeding device, or it may come from a demand signal generator (set point) transmitter.

The belt "transport" signal is preferably inputted as a series of pulses that represent increments of belt travel.

The Scale Location Compensation symbol is read: "Location 'a' Compensated for (location) 'b'.

## USEFUL CONTROL LOOPS

4. A system to control the rate of discharge from a low (belt) speed weigh feeder. Belt speed may be as low as 0.5 feet per minute. If the scale is located 18 inches from the head pulley (a practical consideration), a lag form point of measurement to discharge of 1.5 minutes exists. This obviously not conducive to tight control of the discharging stream.

**Block diagram of proposed system:**

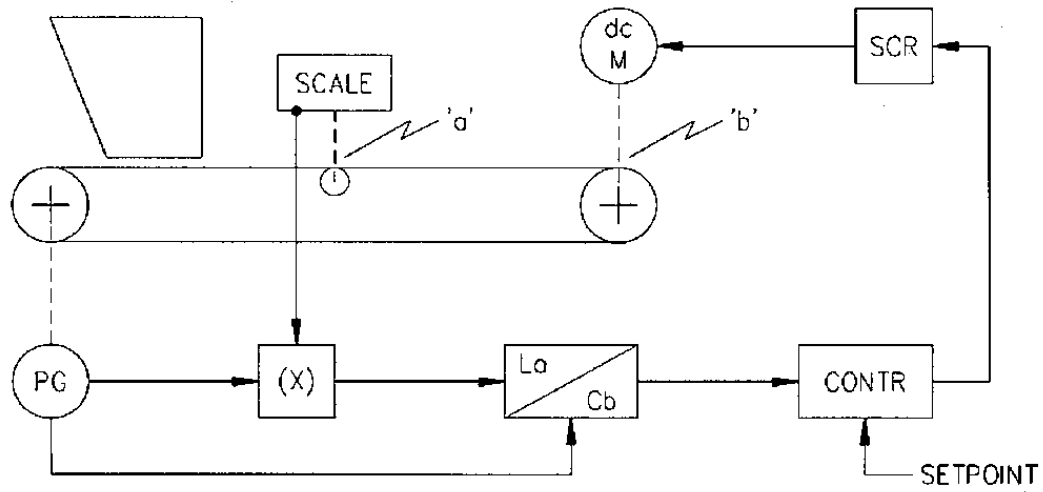

5. A system to measure the discharging quantity of flow from a load out conveyor. Scale should be located near material loading point from the standpoint of accuracy since lower belt tensions are conducive to high accuracy belt weighing. Of primary interest however is the quantity that has been delivered at the head pulley.

**Block diagram of proposed system:**

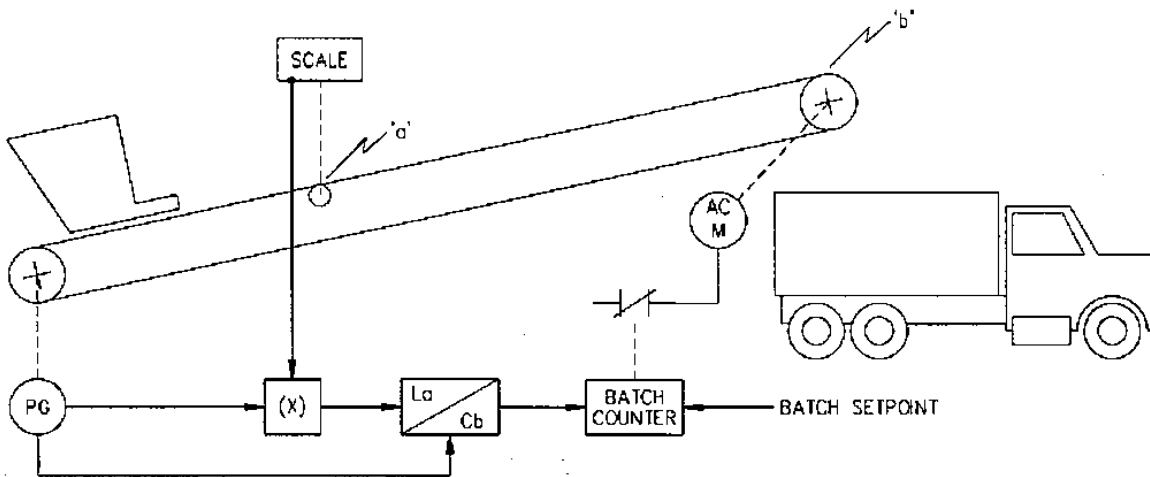

6. This system reports the measured variables discharging into a hostile environment while maintaining tight control of the weigh feeder that must be located a suitable distance away. The transport conveyor belting (steel belting in this example) may be chosen without restriction since the actual weighing is accomplished before the material is transferred to it.

**Block diagram of proposed system:**

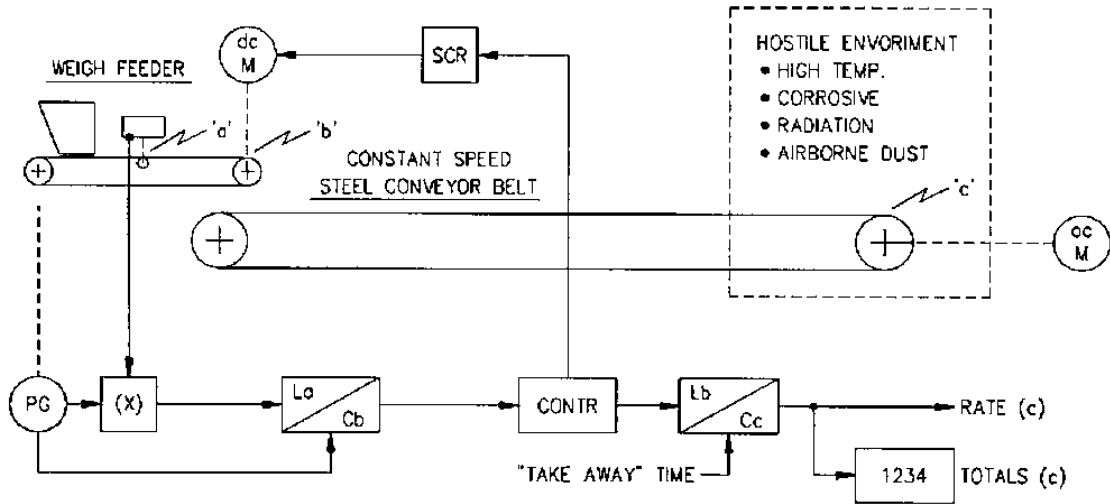

7. Here is a system to achieve correct "in-phase" proportioning of material added to a primary "wild" flow, while eliminating material wastage at the beginning and end of the operating cycle. The wild flow scale's delayed process signal arrives downstream at the additive feeder's ratio station at the same time that the wild flow material reaches the additive feeder. The additive feeder only runs when the wild flow material is present at its location, thus eliminating material waste at the beginning and end of process runs while maintaining in phase blending during the run.

**Block diagram of proposed system:**

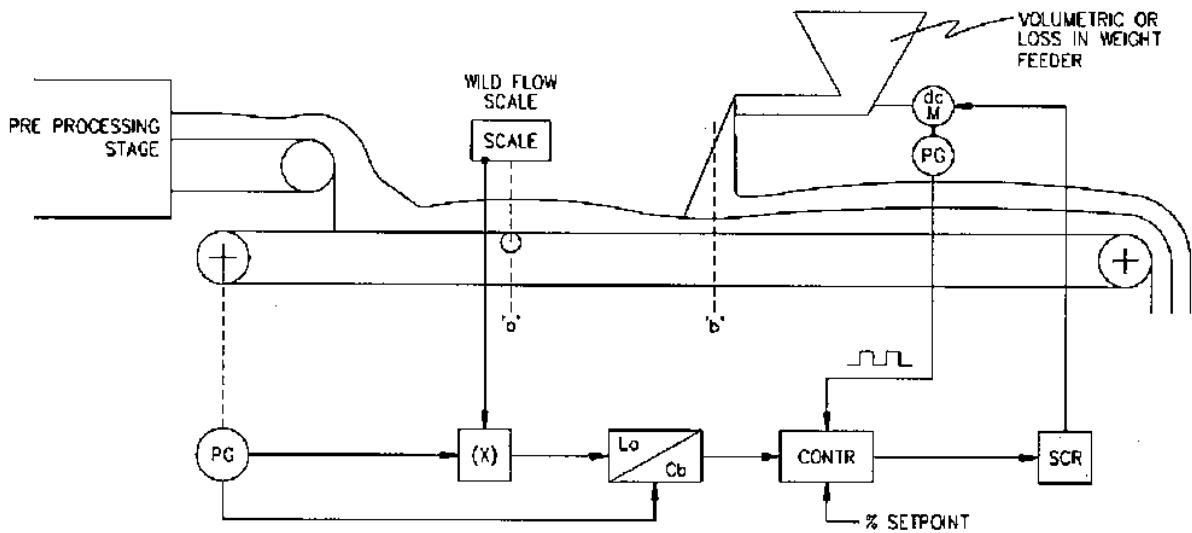

8. A Master Rate Setter station provides this system with a combined flow set point from which each ratio controller operates. Scale Location Compensation is used to delay the input demand to each downstream controller to assure complete "in-phase" blending along the entire length of the collecting conveyor. At the completion of the batch all feeders shut down in the reverse sequence, assuring blend accuracy throughout the entire run.

**Block diagram of proposed system:**

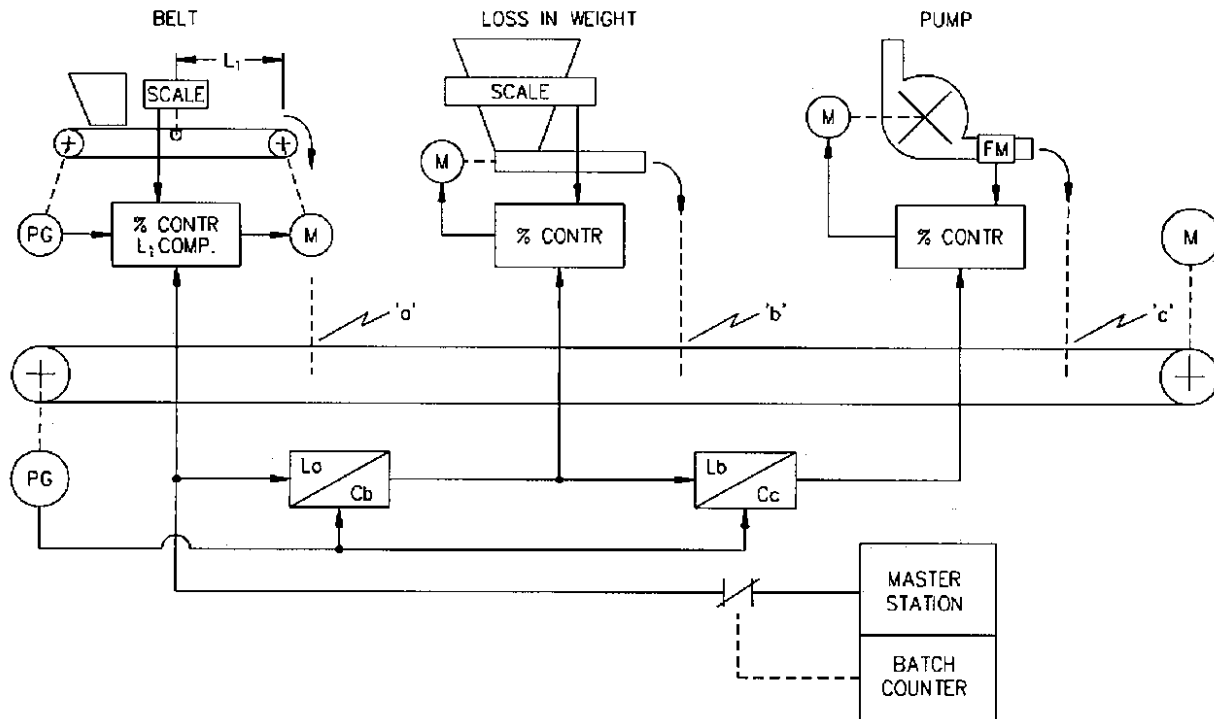

9. As an alternative to the Combined Flow Master Station, the first feeder can be set up as the Master in a conventional "Master-Slave" system. This arrangement assures that the Slaved feeders are paced from the Master feeder's actual flow rate measurement (as opposed to its flow rate set point). While this arrangement is desirable in situations where the reliability of the master ingredient, feed system is suspect, there is a greater likelihood that the feeder will be slightly out-of-phase at times. The reasons for this are:

1. The demand signals that the slaves must follow are dynamic and thus "noisier" and
2. The response lag of the master feeder's delivered output adds a degree of variability to the effective scale location compensation being provided.

**Block diagram of proposed system:**

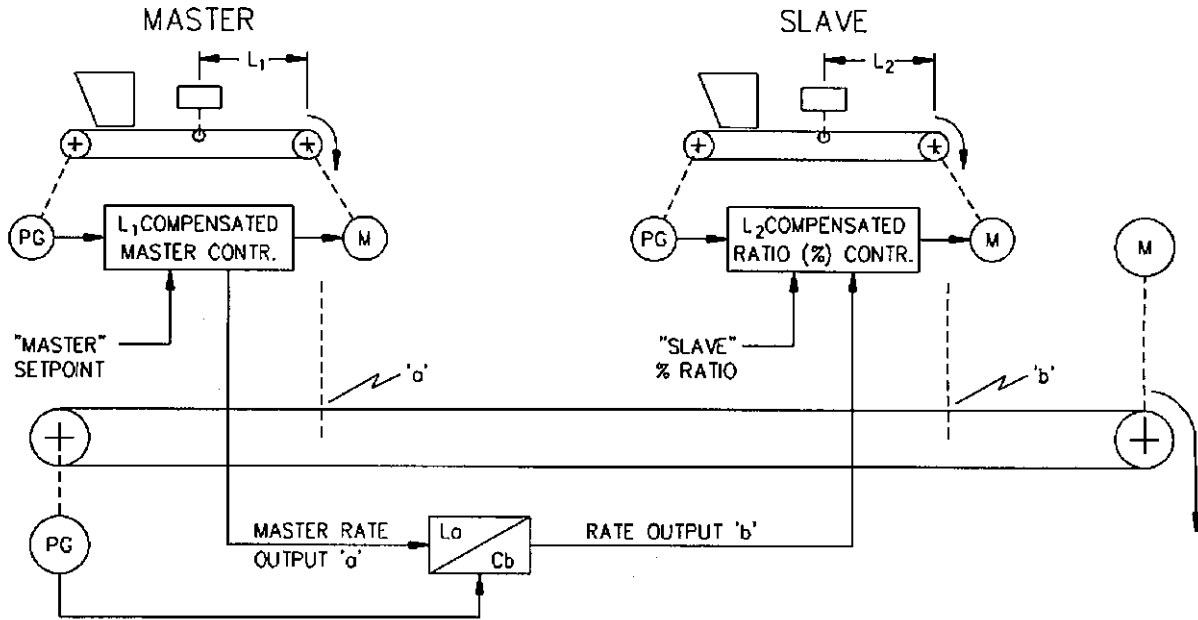

**CONCLUSION**

It has been the purpose of this presentation to re-introduce a control technology which has been available from our company for many years. With soaring raw material costs, and tighter quality standards, refinements to the way we measure and control are of greater importance than ever before. It is hoped that the few example control loops presented here may serve the reader well in his/her never ending quest for improved process control.

References:

1. Hyer, F.S. and Karosas, R.: Positional Transformation of Weight Data; Patent No. 4126196
2. Hyer, F.S. and Karosas, R.: Positional Transformation of Weight Data; Patent No. Re.29944
3. Hyer, F.S. and Gilmore, D.R.: Designing Continuous Weighing Systems using Positional Transformation of Weight Data Paper presented at the Joint Meeting of Canadian Institute of Mining and Instrument Society of America; Oct 10-15, 1976, Vancouver, Canada
4. Colin, H., Weighing and Proportioning of Bulk Solids; 2<sup>nd</sup> Edition, Trans Tech Publications, Clausthal-Zellerfeld Germany, 1983, pp. 340-343