



**BUILT SMART
BUILT TO SURVIVE**

Model PFM-1A2-S Flexure Scale Loss-In-Weight Screw Feeder

- Precise and reliable feeding of cohesive, easily aerated and difficult to control powders.
- Handles a wide range of material bulk densities at low to medium feed rates.
- Patented “compound flight” feed screw design works in conjunction with patented “U-trough” feed chamber to eliminate common problems associated with feeding powders such as screw starvation and binding.
- “FMSS” Mass counterbalanced, electronic weigh scale features high precision measurement, exceptional durability and excellent long term stability. Scale system weighs only the material, not the feeder, for minute-to-minute accuracy and sensitivity.

The THAYER Model PFM-1A2-S is a low to medium capacity Loss-In-Weight Feeder designed to assure uniform, non-pulsating accurate feeding of a wide range of materials, from free flowing to friable to cohesive.

Exclusive Powder Feeder Technology.

Patented “U-trough” feed chamber with independently driven agitator assures precise, reliable delivery of material to the feed screw. Eliminates material build-up, controls material aeration and delivers a steady constant flow of material.

Optional (patented) “compound flight” feed screw design works in conjunction with the “U-trough” feed chamber to eliminate common problems associated with feeding powders.

Fast and easy to clean.

The PFM-1A2-S is designed for fast, easy and thorough clean out. Feeder completely disassembles in less than one minute. High quality, rugged, stainless steel construction assures years of reliable, trouble free operation even in the most severe industrial environments.



“U” Trough with Power Bar



Specialized scale design assures reliable, accurate metering.

The heart of any gravimetric feeder is its scale system. The PFM-1A2-S incorporates a unique flexure suspension scale designed exclusively for use on Loss-In-Weight Feeders:

- High efficiency “dead load” counterbalancing
- Non-tilting platform design
- Tolerant of shocks and overloads
- Mechanical force “summing” to a single load sensor
- Full range sensor utilization = maximum resolution
- Low mechanical resonance frequency
- Easily adapted to future re-rates

Conventional platform scales are NOT well suited for this service. Single point platforms are unsuitable for supporting machinery having this degree of vertical height and elevated mass. They are very vulnerable to side loading and other “tilting” disturbances. Multiple load cell platforms are unsuitable for low loading applications where forces no greater than that of an operator standing on one corner of the platform can cause damage. Finally, both types of platform scales resonate at frequencies much nearer the disturbing frequencies of other processing machinery driven by motors or vibratory drives. While electronic or software filtering may smooth out signal levels, they offer no protection to the load cells.

Thayer Scale-Hyer Industries, Inc.

P.O. Box 669, 91 Schoosett Street, Pembroke, MA 02359

Ph: (781) 826-8101 FAX: (781) 826-7944

E-MAIL Sales@ThayerScale.com

THAYER Model PFM-1A2-S Loss-In-Weight Feeder

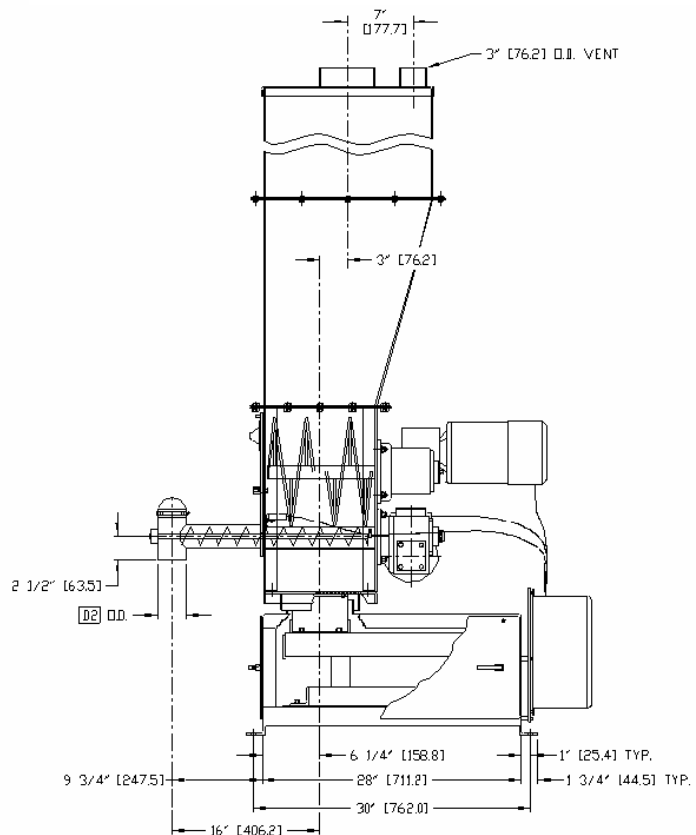
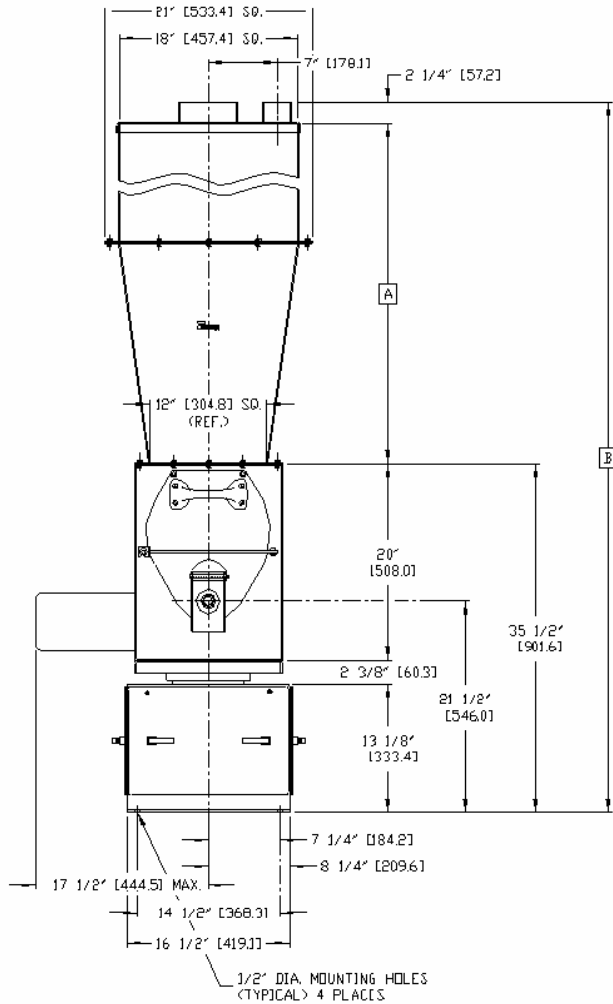

HOPPER EXTENSION

HOPPER CAPACITY	A	B
5.25 C.F. [149 C.M.]	12' [304.8]	72 1/4' [1835.2]
7.50 C.F. [212 C.M.]	24' [609.6]	84 1/4' [2140.0]
9.75 C.F. [276 C.M.]	36' [914.4]	96 1/4' [2444.8]

SPECIFICATIONS

*All dimensions are subject to change, for reference only

Feed Rate: Up to 25 ft³/hr (0.70 m³/hr) at a material bulk density of 50 lbs/ft³ (0.8 gr/cm³). Consult factory for higher feed rates.

Screw Sizes: range from 1.5" Ø. (variable pitch) to 2.0" Ø (variable pitch) solid flight or open helix with center through shaft.

Scale Type: "FMSS" Flexure Scale System (dead load is mass-counterbalanced) and Strain Gauge Load Sensor.

Scale Capacity (live load): variable up to 500 lbs (227 kg).

Hopper Capacity: 2.25 ft³ hopper expandable to 9.75 ft³ with hopper extensions.

Feeder Drive: 0.75 to 1.5 HP max., variable speed DC motor, 90 or 180V armature, TENV.

-AC TEFC, Inverter Duty, 230 or 460 motor available.

-Wash Down, Chemical Duty and Explosion Proof available.

Trough Agitator: Independently driven, constant speed, horizontal mount with 0.5 HP, (0.37 kW AC motor 230/460) Continuously conditions material to aid in de-aeration & maintain a uniform bulk density.

Material Contact Surface: Electro-polish (material contact parts) or mill finish 304 and 316 Stainless Steel, other finishes available.

Non-Material Contact Surfaces: Carbon steel painted with primer and industrial grade enamel paint (special coatings and stainless steel available upon request).

Temperature Range-Material: 32°F (0°C) to 130°F (55°C) standard. Consult factory for other temperatures.

Accuracy: 0.25% to 1% of set rate ±2 sigma based on a minimum sample of one (1) minute, 30 revolutions of the screw or 1% of scale capacity.

Options:

•**Sanitary Construction.**

•**Hazardous Area Modifications:** includes UL/CSA approved explosion proof motors and FM approved I.S. Barriers for weight and speed signals.

•**Sanitary Construction.**

Thayer Scale-Hyer Industries, Inc.

P.O. Box 669, 91 Schoosett Street, Pembroke, MA 02359

Ph: (781) 826-8101 FAX: (781) 826-7944

E-MAIL Sales@ThayerScale.com