



**BUILT SMART  
BUILT TO SURVIVE**

## Model PF-SC-S Loss-In-Weight Screw Feeder with Mass Flow Hopper

### Features:

- Accurately measures load regardless of load position.
- Immune to support structure deflections and process vibrations.
- Inherently self aligning to gravity.
- Nulls out heavy tare loads.
- 1,000% over load capacity.
- Scale may be suspended from above or supported below.
- Immune to shock or impact loads.
- Easily accessible load cell can be re-rated to meet future capacity changes without removing the feeder.

The THAYER Model PF-SC-S is a medium capacity Loss-In Weight-Feeder designed to assure accurate and uniform feeding of a wide range of materials, from free flowing to very fine cohesive powders.

### Exclusive Powder Feeder Technology.

Patented “U-trough” feed chamber with independently driven agitator assures precise, reliable delivery of material to the feed screw. Eliminates material build-up, controls material aeration and delivers a steady constant flow of material.

Optional (patented) “compound flight” feed screw can be used with most materials to downwardly extend the operating range of the feeder by a factor of 10 (typically).

### Fast and easy to clean.

The PF-SC-S is designed for fast, easy and thorough clean out. Feeder completely disassembles in less than one minute. High quality, rugged, stainless steel construction assures years of reliable, trouble free operation.

### Patented “FMSS” (Force Measurement Suspension System) Cable Scale Technology.

The Thayer Cable Scale (patented) is the most rugged and forgiving Load Cell Weighing System available on the market. It can take more physical abuse and can tolerate more foundation distortion/deflection than all other known designs.

The exclusive Thayer Scale “FMSS” Cable Suspension design provides extremely high sensitivity. Feeder “dead load” is mass-counterbalanced so that only material weight (*live load*) is measured. This feature helps assure excellent control in “noisy” environments.



All of the articulate parts of the scale mechanism are supported from “*axially inextensible, but laterally yieldable*” suspension elements (stainless steel pre-stressed aircraft cable, which are arranged to hang freely) vertically throughout their lengths under all operating conditions, thereby avoiding any appreciable spring or hysteresis effects, variations in mechanical advantage, or binding due to imperfect leveling.

Because of this unique mechanical property of the force transmission system, any laterally directed forces and shocks on the scale or its supported machinery can not cause destructive shear and bending stresses to develop in the elements themselves or at the load cell junction. The system, being yieldable in the lateral direction, is therefore effectively and completely protected by using laterally placed “stops” in proximity of the weighed structure.

Weight loss is measured by a highly accurate, very sensitive, high output electronic force measurement sensor. The Thayer Series LC-137 weight resolver is a force measuring device designed specifically for use with Thayer Scale weighing systems. It is a precision-built, heavy duty device designed for long term stability and accuracy under the most demanding applications. It is initially calibrated and installed by the factory and normally requires no routine maintenance. So rugged is the “FMSS” Scale system that the LC-137 Weight Resolver is guaranteed for 15-years.

## Thayer Scale-Hyer Industries, Inc.

P.O. Box 669, 91 Schoosett Street, Pembroke, MA 02359

Ph: (781) 826-8101 FAX: (781) 826-7944

E-MAIL Sales@ThayerScale.com

# THAYER Model PF-SC-S Loss-In-Weight Feeder

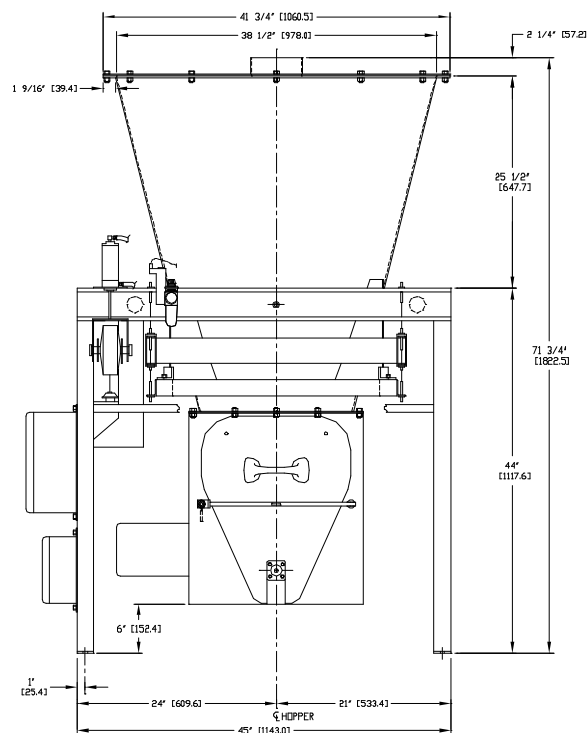
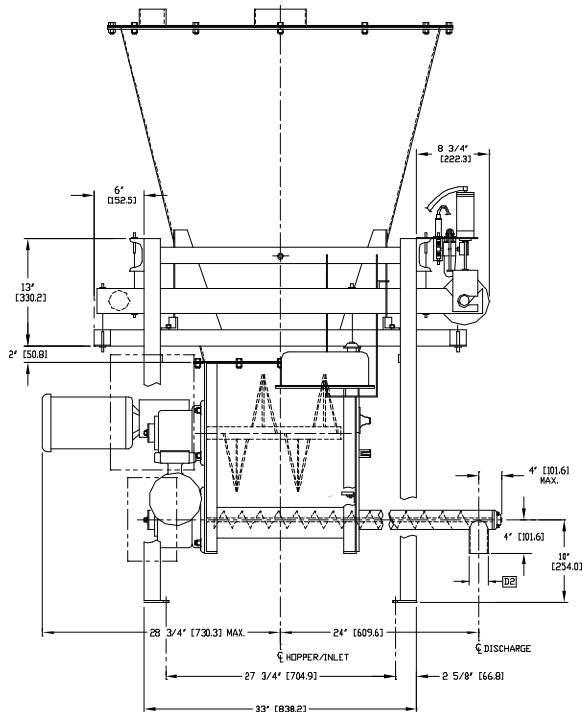

D2		D1	
1 1/4"	(31.8)	6"	(152.4)
1 3/4"	(44.5)	8"	(203.2)
2 1/4"	(57.2)	10"	(254.0)
3 1/4"	(82.6)	12"	(304.8)
3 3/4"	(95.6)		
4 1/2"	(114.3)		
5"	(127.0)		

\*All dimensions are subject to change, for reference only.

## SPECIFICATIONS

**Volumetric Capacity:** Up to 205 ft<sup>3</sup>/hr (7.08 m<sup>3</sup>/hr). Consult factory for higher feed rates.

**Screw Sizes:** range from 2.0" Ø. (variable pitch) to 4.0" Ø (variable pitch) solid flight or open helix with center through shaft.

**Scale Type:** "FMSS" Cable Scale System (dead load is mass- counterbalanced) and Model LC137 weight resolver.

**Scale Capacity (live load):** variable up to 500 lbs (227 kg).

**Hopper Capacity:** 2.25 ft<sup>3</sup> hopper expandable to 11.25 ft<sup>3</sup> with hopper extensions.

**Feeder Drive:** 1.0 to 1.5 HP max., variable speed DC motor, 90 or 180V armature, TENV.

-AC TEFC, Inverter Duty, 230 or 460 motor available.

-Wash Down, Chemical Duty and Explosion Proof available.

**Trough Agitator:** Independently driven, constant speed, horizontal mount with 0.5 HP, (0.37 kW AC motor 230/460) Continuously conditions material to aid in de-aeration & maintain a uniform bulk density.

**Material Contact Surface:** Electro-polish (material contact parts) or mill finish 304 and 316 Stainless Steel, other finishes available.

**Non-Material Contact Surfaces:** Carbon steel painted with primer and industrial grade enamel paint, (special coatings and stainless steel available upon request).

**Temperature Range-Material:** 32°F (0°C) to 130°F (55°C) standard. Consult factory for other temperatures.

**Accuracy:** 0.25% to 1% of set rate ±2 sigma based on a minimum sample of one (1) minute, 30 revolutions of the screw or 1% of scale capacity.

**Automated Test Weight Lifter Assembly (ATWL):** Used to automatically conduct a zero and span calibration.

### Options:

•**Hazardous Area Modifications:** includes UL/CSA approved explosion proof motors and FM approved I.S. Barriers for weight and speed signals.

•**Sanitary Construction.**

## Thayer Scale-Hyer Industries, Inc.

P.O. Box 669, 91 Schoosett Street, Pembroke, MA 02359

Ph: (781) 826-8101 FAX: (781) 826-7944

E-MAIL Sales@ThayerScale.com