



**BUILT SMART
BUILT TO SURVIVE**

Model SI-15 Insertion Weigh Belt Module (scale under configuration)

The THAYER “SI” Insertion Weigh Belt Module has been designed to easily fit into an existing belt or vibratory conveyor line. A short support framework and a suspended 24” (inch) long “V-Guided” conveyor (12”, 18” and 24” wide) makes this the only practical weighing module for insertion into a short transition space between existing conveyors or equipment. Unique benefits result from suspending a short “V-Guided” conveyor from the model 15L Force Measurement Suspension System (15L-FMSS).

Since load measurements are not affected by the physical characteristics of the belting and its supporting means (stiffness, sliding friction, non-uniformity, splice effects, tension/misalignment interaction, etc.) the construction of the belting and its material can be chosen on the basis of durability and belt-tracking ability without concern for accuracy compromise. Also, on new installations, the combination of the most suitable volumetric pre-feeder and the Series SI

often proves the best approach considering cost, available space, and materials handling requirements.

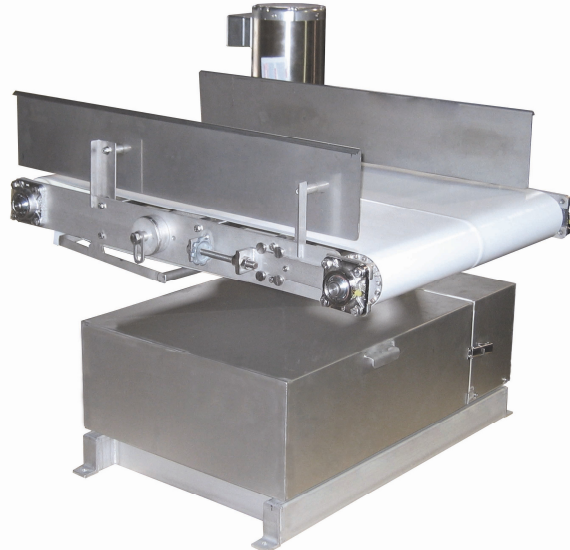

The conveyor portion is normally 24” long and is suspended from the scale on an open cantilevered “C-Frame” pipe support, which greatly simplifies belt removal and replacement for wash down applications. Belt widths of 12”, 18” and 24” are available. Because the belting is more robust than that used for “under-the-belt” load sensing feeders, and because the belt is positively tracked using a V-Guided tracking system, the operating life of the belt is substantially longer than with conventional designs. The conveyor portion can be oriented on the C-Frame to convey horizontally, upwards (20 degrees) or downward (20 degrees), in whatever configuration best suits the installation conditions. The combination of gear reducer/motor is supplied for wash down service, and is available in either constant or variable speed applications.

The SI Insertion Weigher uses Thayer Scale’s model 15L precision flexure plate suspension scale with FMSS technology. The scale provides for complete mass counterbalancing of the dead load of the conveyor permitting the load sensor to react only to the net material load. This unique system is not affected by dirt, shocks or vibration, and can withstand overloads in excess of 1,000 pounds without causing damage or affecting calibration. The highly advanced and extremely robust sensing technology is based on the marriage of the LVDT, embedded temperature sensing and proprietary linearizing and temperature compensating algorithms.

The Series “SI” can be supplied with THAYER instrumentation and controls to function as either a process stream weigher only, or as a flow stream controller/weigher (providing the additional controller output to regulate the upstream delivery system). Thayer Scale’s patented “SLC” (scale location compensation) features can also be supplied to move the point of measurement further downstream adjacent to associated or “slaved” equipment.

Thayer Scale-Hyer Industries, Inc.

P.O. Box 669, 91 Schoosett Street, Pembroke, MA 02359

Ph: (781) 826-8101 **FAX:** (781) 826-7944

E-MAIL Sales@ThayerScale.com

THAYER "SI" Insertion Weigh Belt Module

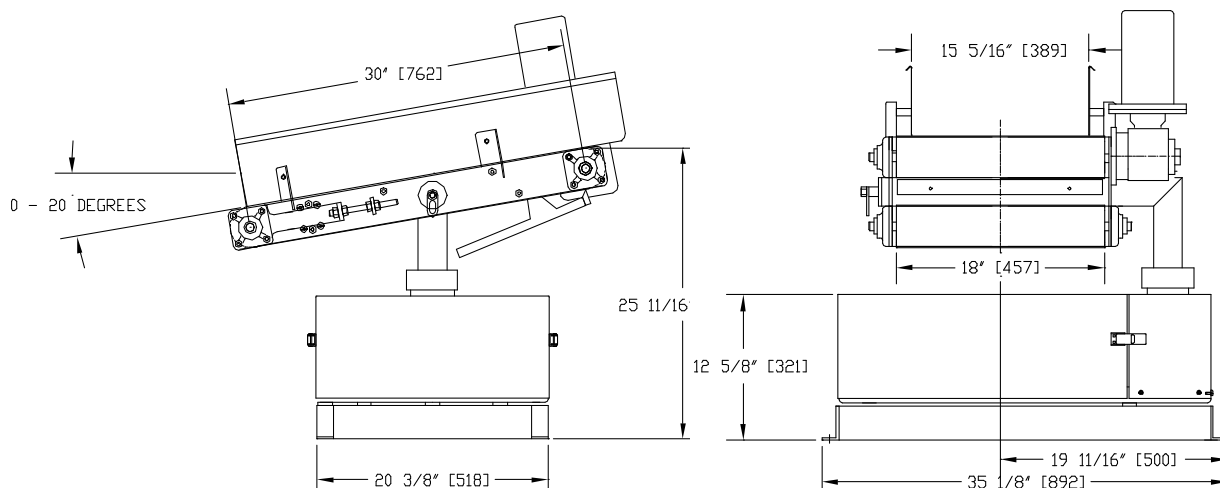

*All dimensions are subject to change, for reference only.
18" wide belt shown, wider belts available.

SPECIFICATIONS

Capacity:

Up to 0.56 ft³/ft @ 5 in. bed depth (0.052 m³/m @ 12.7 cm bed depth).

Loading Range:

1 - 15 lb/ft (1.5 - 22.3 kg/m)

Belt Speed (max):

30, 50, 75 or 100 ft/min (9.1, 15.2, 22.9 or 30.5 m/min)

Turndown:

20:1 overall (4:1 load turndown at a particular belt speed; 5:1 belt speed turndown from max speed).

Belt Width:

18 inch (457 mm) nominal. (optional widths available)

Accuracy:

+ ½ to 1% of set rate @ 2 sigma based on a minimum sample of 1 minute or 10 circuits of the belt, whichever is greater.

Weight Measurement System:

Mass-counterbalanced Force Measurement Suspension System (FMSS).

Precision electronic load cell.

Speed Measurement System:

High resolution digital pulse tachometer.

Material of Construction:

304 or 316 stainless steel.

Belt:

Two-ply polyester fabric with V-guide, spliced endless, manufactured to FDA standards.

Motor and Controller:

Standard motor – 0.25 HP, 90 VDC, TENV, service factor 1.5, class B insulation.

Standard motor drive – manually variable speed, 115 VAC, 1Ø, 50/60 Hz input power mounted in NEMA 4 enclosure.

Optional motors and drives available.

Drive Reducer:

Direct-coupled, right angle worm & gear type, service factor 1.5, complies with AGMA standards.

Drive Connection:

Roller chain and sprocket, service factor 1.5, totally enclosed chain guard.

Temperature limits:

Ambient 32°F – 130°F (0°C – 54°C).

Process material 0°F – 200°F (-18°C – 93°C).

Conveyer configurations:

Conveyer can be installed inclined 20°, horizontal, or declined 20°.

Weigh Belt Construction:

Open flow channel with side skirt boards (sealing strips optional).

Options:

•**Hazardous Area Modifications:** includes UL/CSA approved explosion proof motors and FM approved I.S. Barriers for weight and speed signals

Thayer Scale-Hyer Industries, Inc.

P.O. Box 669, 91 Schoosett Street, Pembroke, MA 02359

Ph: (781) 826-8101 FAX (781) 826-7944

E-MAIL Sales@ThayerScale.com