



**BUILT SMART
BUILT TO SURVIVE**

Model LWF-LC-V Loss-In-Weight Vibratory Feeder

Features:

- Accurately measures load regardless of load position.
- Immune to support structure deflections and process vibrations.
- Inherently self aligning to gravity
- Nulls out heavy tare loads.
- 1,000% over load capacity.
- Scale may be suspended from above or supported below.
- Immune to shock or impact loads.
- Easily accessible load cell can be re-rated to meet future capacity changes without removing the feeder.

The THAYER LWF-LC-V is a large capacity Loss-In-Weight Feeder is designed to assure uniform, non-pulsating accurate feeding of a wide range of materials, from free flowing to friable to cohesive.

The LWF-LC-V can be configured to be used in conjunction with many different styles of electromagnetic pan feeders up to 48" wide.

Patented "FMSS" (Force Measurement Suspension System) Cable Scale Technology.

The Thayer Cable Scale (patented) is the most rugged and "forgiving" Load Cell Weighing System available on the market. It can take more physical "abuse" and can tolerate more foundation distortion/deflection than all other known designs.

The exclusive Thayer Scale "FMSS" Cable Suspension design provides extremely high sensitivity. Feeder "dead" load (feeder and weigh hopper) is mass-counterbalanced so that only material weight (*live load*) is measured. This feature helps assure excellent control in "noisy" environments.

All of the articulate parts of the scale mechanism are supported from "*axially inextensible, but laterally yieldable*" suspension elements (stainless steel pre-stressed aircraft cable, which are arranged to hang freely) vertically throughout their lengths under all operating conditions, thereby avoiding any appreciable spring or hysteresis effects, variations in mechanical advantage, or binding due to imperfect leveling.

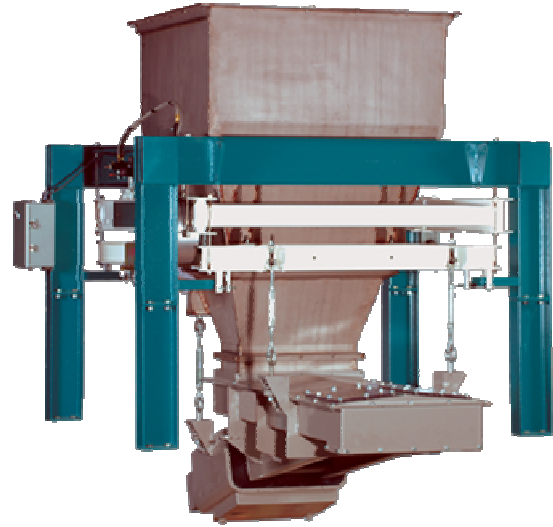

Shown with a 40 ft³ hopper and 36" wide pan

Because of this unique mechanical property of the force transmission system, any laterally directed forces and shocks on the scale or its supported machinery can not cause destructive shear and bending stresses to develop in the elements themselves or at the load cell junction. The system, being yieldable in the lateral direction, is therefore effectively and completely protected by using laterally placed "stops" in proximity of the weighed structure.

Weight loss is measured by a highly accurate, very sensitive, high output electronic force measurement sensor. The Thayer Series LC-137 weight resolver is a force measuring device designed specifically for use with Thayer Scale weighing systems. It is a precision-built, heavy duty device designed for long term stability and accuracy under the most demanding applications. It is initially calibrated and installed by the factory and normally requires no routine maintenance. So rugged is the "FMSS" Scale system that the LC-137 Weight Resolver is guaranteed for 15-years.

Thayer Scale-Hyer Industries, Inc.

P.O. Box 669, 91 Schoosett Street, Pembroke, MA 02359

Ph: (781) 826-8101 FAX: (781) 826-7944

E-MAIL Sales@ThayerScale.com

THAYER Model LWF-LC-V Loss-In-Weight Vibratory Feeder

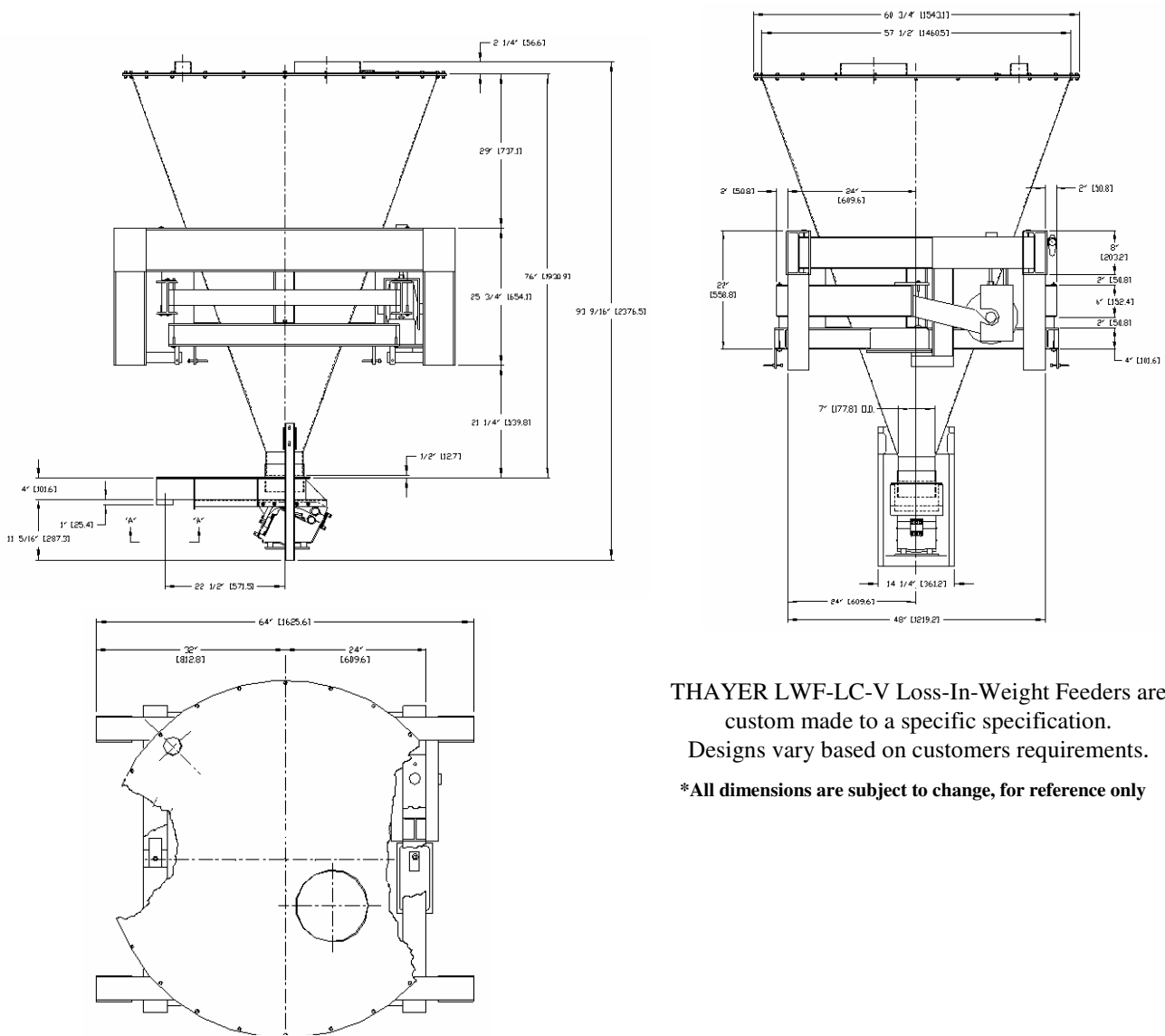

THAYER LWF-LC-V Loss-In-Weight Feeders are custom made to a specific specification. Designs vary based on customers requirements.

*All dimensions are subject to change, for reference only

SPECIFICATIONS

Volumetric Capacity: Consult Factory.

Vibrating Feeder Drive: Electromagnetic Drive.

Scale Type: "FMSS" Cable Scale System (dead load is mass-counterbalanced) and Model LC-137 Weight Resolver.

Scale Capacity (live load): variable up to 2,200lbs (998 kg).

Hopper Capacity: 20 to 60ft³, consult factory for larger sizes.

Material Contact Surface: Carbon Steel, Electro-polish (material contact parts) or mill finish 304 and 316 Stainless Steel, other finishes available.

Non-Material Contact Surfaces: Carbon steel painted with primer and industrial grade enamel paint, (special coatings and stainless steel available upon request).

Temperature: 32°F (0°C) to 130°F (55°C) standard. Consult factory for other temperatures.

Accuracy: 0.25% to 1% of set rate ±2 sigma based on thirty 1 minute samples or 1.0% of weigh hopper storage capacity, whichever is greater.

Automated Test Weight Lifter Assembly (ATWL): Used to automatically conduct a zero and span calibration.

Options

•**Hazardous Area Modification:** Consult Factory.

•**Sanitary Construction.**

Thayer Scale-Hyer Industries, Inc.

P.O. Box 669, 91 Schoosett Street, Pembroke, MA 02359

Ph: (781) 826-8101 FAX: (781) 826-7944

E-MAIL Sales@ThayerScale.com