



**BUILT SMART
BUILT TO SURVIVE**

Model LWF-801-LRF Platform Scale Loss-In-Weight Screw Feeder

- Precise and reliable feeding of fine powders and granules.
- Rugged industrial scale with laboratory accuracy.
- No tools necessary for cleaning or making changeovers.
- Load sensor fully protected from shocks and overloads.
- Stainless Steel Construction.

Exclusive “MICRO” Powder Feeder Technology

Simply scaling down a conventional volumetric feeder to a degree where diameters and clearances are a fraction of those on larger equipment, leads to all kinds of reliability and material handling difficulties. The THAYER “LRF”, while embodying various features common to Thayer Scale’s other lines of equipment, was designed from scratch based on hard work, experimentation, and applicable field work. Not surprisingly, micro-sized bulk material feeding equipment is more dependent on *the interaction between all material contacting elements*, including those that are active and those that are passive.

The unique combination of the vertical-wall supply hopper, a preconditioning trough/chamber containing a special horizontal agitator that is directly synchronized to screw speed, a smooth, no-”step-up” trough-to-feed tube transition (eliminating the usual “stagnation” zone), and a properly selected auger (5 types available), all working in unison, accounts for the “LRF’s” superior performance and reliability.

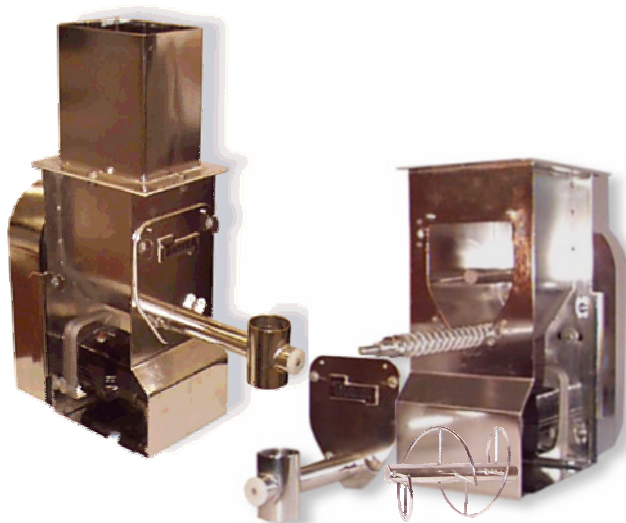

Flexure Scale assures reliable, accurate metering.

The heart of any gravimetric feeder is its scale system. The LWF-801-LRF incorporates a unique flexure suspension scale designed exclusively for use on Loss-In-Weight Feeders:

- High efficiency “dead load” counterbalancing.
- Non-tilting platform design.
- Tolerant of shocks and overloads.
- Mechanical force “summing” to a single load sensor.
- Full range sensor utilization = maximum resolution.
- Low mechanical resonance frequency.
- Easily adapted to future re-rates.

No tools required for Changeovers or Cleaning

The LWF-801-LRF is designed for fast, easy and thorough clean out. Feeder completely disassembles without tools in less than one minute. High quality, rugged, stainless steel construction assures years of reliable, trouble free operation even in the most severe industrial environments.

Thayer Scale-Hyer Industries, Inc.

P.O. Box 669, 91 Schoosett Street, Pembroke, MA 02359

Ph: (781) 826-8101 FAX: (781) 826-7944

E-MAIL Sales@ThayerScale.com

THAYER Model LWF-801-LRF Loss-In-Weight Feeder

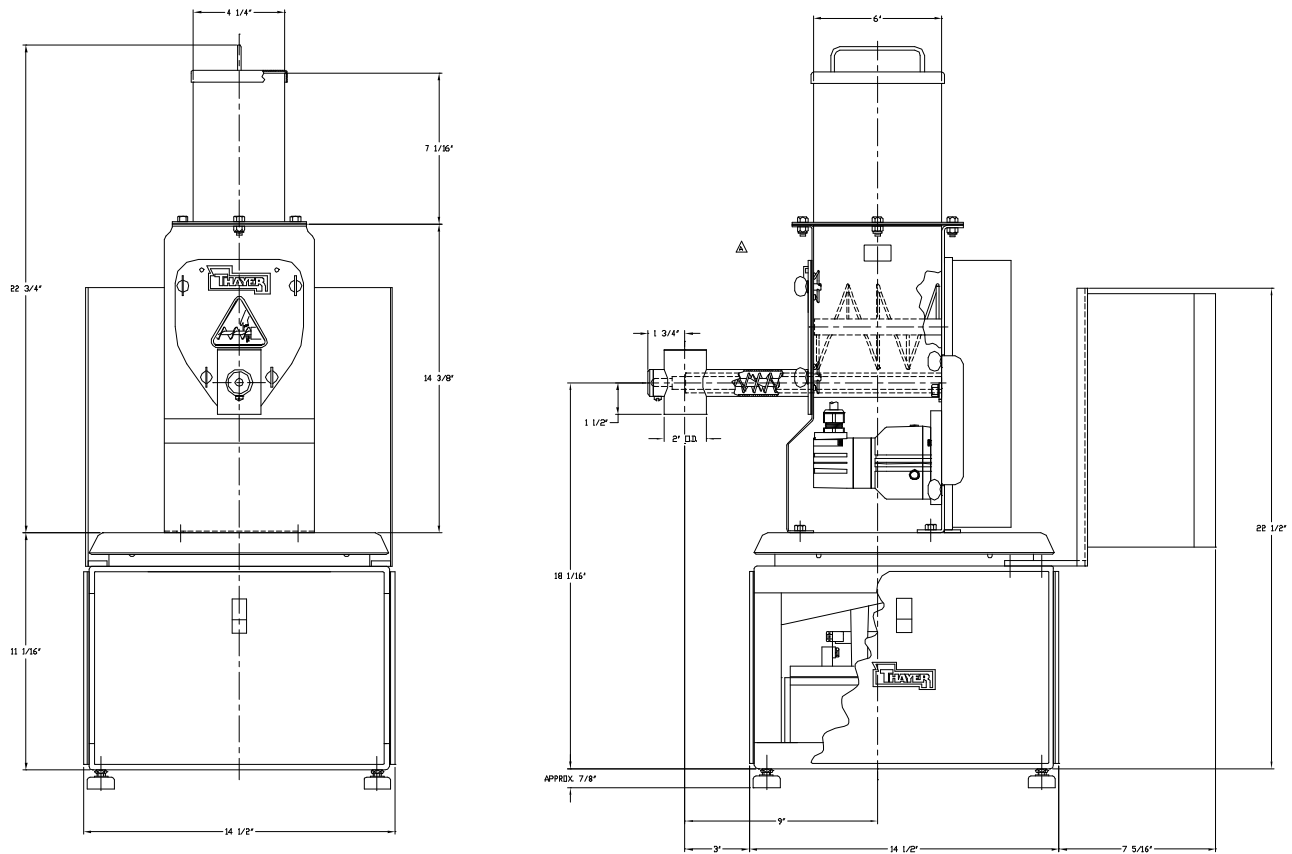

*DIMENSIONS

*All dimensions are subject to change, for reference only

SPECIFICATIONS

Volumetric Capacity:

1.0 to 100 lbs/hr with 20 to 1 turndown.
Density Range: 10-100 pcf.

Accuracy:

0.25% to 1.0% of set feed rate ± 2 sigma based on a minimum of 30 samples of one (1) minute, 30 revolutions of the screw, or 1% of scale capacity, whichever is greater.

Scale Type:

Flexure Scale System with "FMSS" Technology dead load mass counterbalanced.

Scale Capacity:

5 to 25 lb.

Operating Temperature Range:

32 to 130°F (0 to 55°C).

Feeder Drive:

1/16 hp, variable speed brushless DC motor, 120v armature.

Hopper Size:

Standard: 0.1 cubic ft.
Optional hoppers available

Material Contact Surfaces:

Standard Glass Bead, 304 Stainless Steel material contact surfaces.

Option:

electro-polished finish.
(feed screw is mirror finished).

Non-Material Contact Parts:

304 SS – 2B finish.

Thayer Scale-Hyer Industries, Inc.

P.O. Box 669, 91 Schoosett Street, Pembroke, MA 02359

Ph: (781) 826-8101 FAX: (781) 826-7944

E-MAIL Sales@ThayerScale.com