



**BUILT SMART
BUILT TO SURVIVE**

THAYER Model FP-18 Flat Belt Conveyor Scale-Multiple Weigh Idlers

The THAYER "FP" Belt Scales is a unique weighing scale specifically designed to accurately weigh "low density" materials. Weighing deck typically consists of 2 to 6 flat idlers, mounted either horizontally or at an incline of up to 12 degrees, depending on material handled. It can be used in new installations or can be seamlessly integrated into an existing conveyor. Typical application include cereals, snack foods, pet foods, wood fibers, paper waste, tobacco, and textiles (bulk densities ranging from 0.5 to 25 pcf).

Specialized Scale design assures reliable, accurate weighing.

The most important element of the FP Belt Scale is its scale system, which utilizes Thayer Scale's "FMSS" technology (see below). The FP has a unique combination of features that make it ideal for low density belt weighing:

- High efficiency "dead Load" counterbalancing, up to 500 lbs.
- Load sensor sized to utilize its full range for "live load" only
- Calibration maintained under heavy overloading, 1,000+lb.
- Ultra-low deflection (<0.0005 in.) negates belt tension error.
- Non-tilting platform design for conveyor alignment stability.
- Provisions for built in automatic test weight.
- Easy to re-range in the field.

"FMSS" Scale Technology

A Force Measurement Suspension System (FMSS) is the arrangement of active mechanical elements interposed between the load receptor (belt) and load cell. Properly designed, the FMSS functions as a force vector filter that permits the sum of the chosen uni-directions force components to pass through the system to the load cell while blocking all other nuisance, erroneous or destructive force vectors.

The Flexure Plate systems eliminates all wearing parts, such as bearings, pivots and knife edges, and is not susceptible to vibration. Flexure suspension system transfers to a single load transducer, which accurately measures load regardless of load position. Most platform scales are not designed to be immune to side loading and/or torsional loading caused by the plant environment and by the movement of the belt. These factors can cause poor accuracy and poor calibration stability. The Thayer flexure system cancels all horizontal force vectors and also tare loads to be completely mass counter balanced, permitting load cell sizing based on net rather than gross weight.

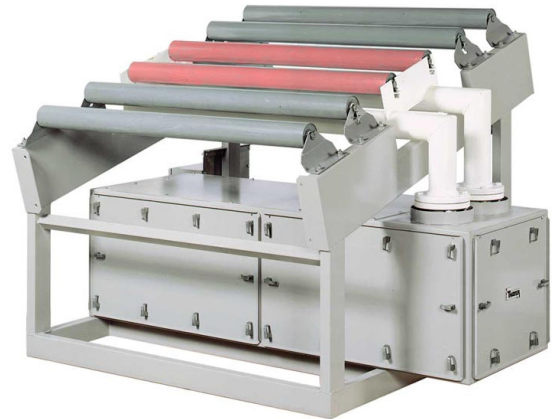

Shown above is an "FP" Belt Scale with 2 idler inclined conveyor section located above scale for installation in a cereal line. Inside of the scale enclosure is a THAYER Automatic Test Weight Lifter ("ATWL") which permits the plant to verify the scale's calibration from a remote location. Two fixed "lead-in" and two fixed "lead-out" idlers are supplied as an integral part of this weigher, to eliminate belt-tension errors. The counterbalanced dead load, including tubular "C" frame support structure, weighbridge, and two weigh idlers, weighs 250 pounds. The live load (weight of cereal) weighs 10 pounds, giving a tare-to-net load ratio of 25. The load sensor is sized for 12 pounds, allowing 83% of the full scale range to be used for the net load measurement. This assures a high signal-to-noise ratio. Two operators weighing 180 pounds each could stand on the weighbridge and would not cause a calibration shift. This "overload" represents 30 times the full scale measurement range of the load sensor. This is one example of the benefit of THAYER "FMSS" technology.

Thayer Scale-Hyer Industries, Inc.

P.O. Box 669, 91 Schoosett Street, Pembroke, MA 02359

Ph: (781) 826-8101 FAX: (781) 826-7944

E-MAIL Sales@ThayerScale.com

Thayer Model "FP" Belt Scale



"FP" Belt Scale – Scale "Over" Design

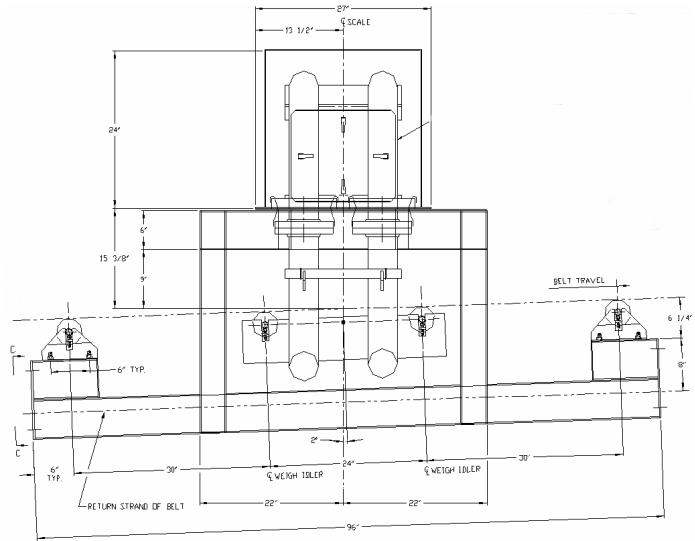

"FP" Belt Scale – Scale "Under" Design

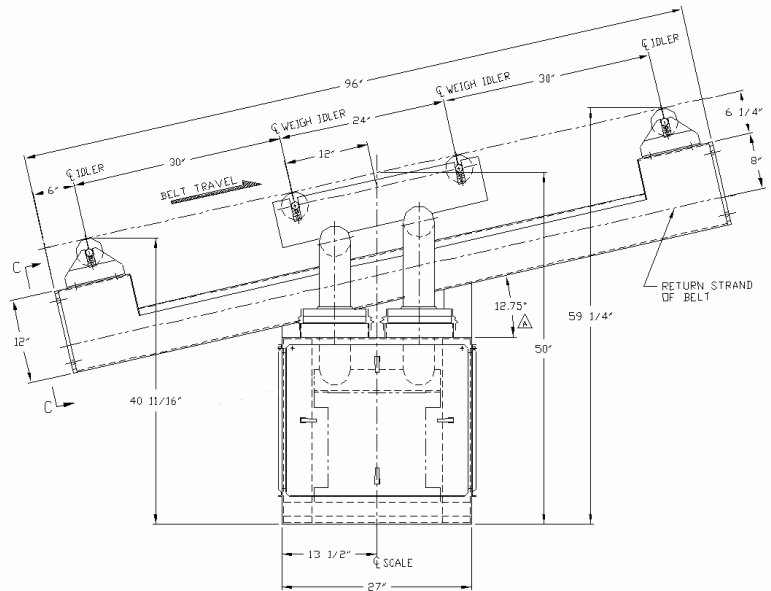

Thayer Model "FP" Belt Scales are custom designed to meet a particular application. Consult the factory for specific design information.

Thayer Scale-Hyer Industries, Inc.

P.O. Box 669, 91 Schoosett Street, Pembroke, MA 02359

Ph: (781) 826-8101 FAX: (781) 826-7944

E-MAIL Sales@ThayerScale.com

THAYER Model "FP" Belt Scale

Scale "Over" Design

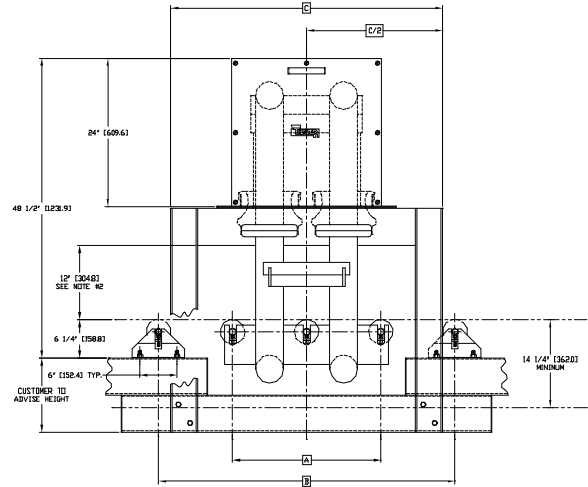
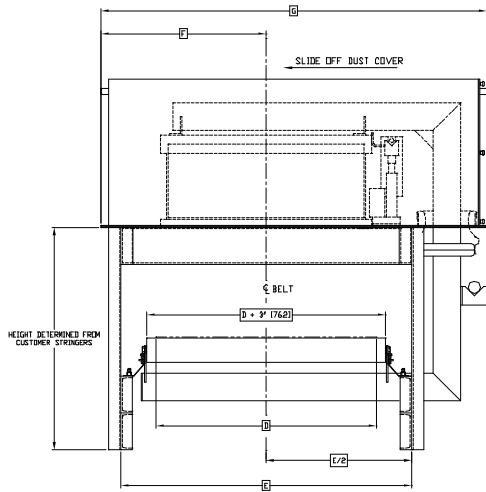

AS SHOWN

WF	'A'	'B'	'C'	# IDLERS
35 FT.	24' [609.6]	60' [1524.0]	44' [1117.6]	3
45 FT.	36' [914.4]	72' [1828.8]	56' [1422.4]	4
55 FT.	48' [1219.2]	84' [2133.6]	68' [1727.2]	5

AS SHOWN

'D' BELT WIDTH	'E'	'F'	'G'
24' [609.6]	35' [889.0]	21' [533.4]	51' [1295.4]
30' [762.0]	41' [1041.4]	24' [609.6]	57' [1447.8]
36' [914.4]	47' [1193.8]	27' [685.8]	63' [1600.2]
42' [1066.8]	53' [1346.2]	30' [762.0]	69' [1752.6]
48' [1219.2]	59' [1498.6]	33' [838.2]	75' [1905.0]
54' [1371.6]	65' [1651.0]	36' [914.4]	81' [2057.4]

Scale "Under" Design

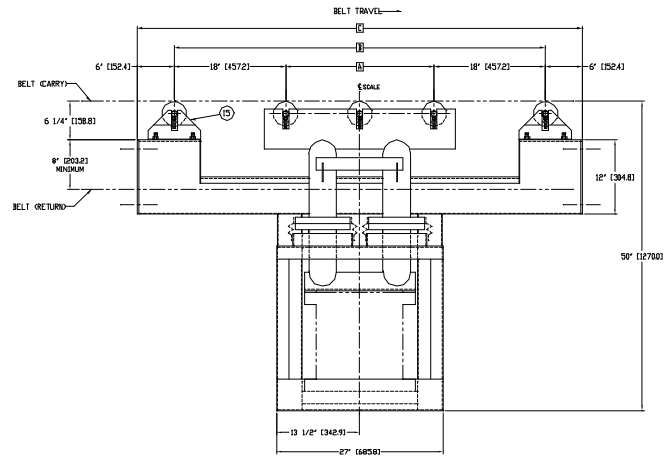
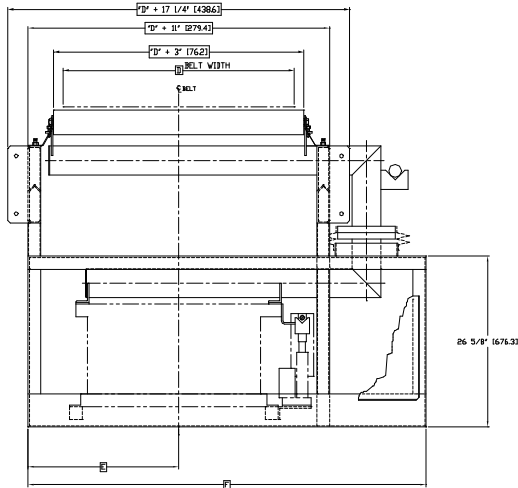

AS SHOWN

WF	'A'	'B'	'C'	# IDLERS
35 FT.	24' [609.6]	60' [1524.0]	72' [1828.8]	3
45 FT.	36' [914.4]	72' [1828.8]	84' [2133.6]	4
55 FT.	48' [1219.2]	84' [2133.6]	96' [2438.4]	5

SHOWN

'D' BELT WIDTH	'E'	'F'
24' [609.6]	17 1/2" [444.3]	50" [1270.0]
30' [762.0]	20 1/2" [520.7]	56" [1422.4]
36' [914.4]	23 1/2" [596.9]	62" [1574.8]
42' [1066.8]	26 1/2" [673.1]	68" [1727.2]
48' [1219.2]	29 1/2" [749.3]	74" [1879.6]
54' [1371.6]	32 1/2" [825.5]	80" [2032.0]

*All dimensions are subject to change, for reference only

Thayer Model "FP" Belt Scales are custom designed to meet a particular application. Consult the factory for specific design information.

Thayer Scale-Hyer Industries, Inc.

P.O. Box 669, 91 Schoosett Street, Pembroke, MA 02359

Ph: (781) 826-8101 FAX: (781) 826-7944

E-MAIL Sales@ThayerScale.com